



**Waukesha
Cherry-Burrell**

®

UNIVERSAL

5000 SERIES

PD PUMPS

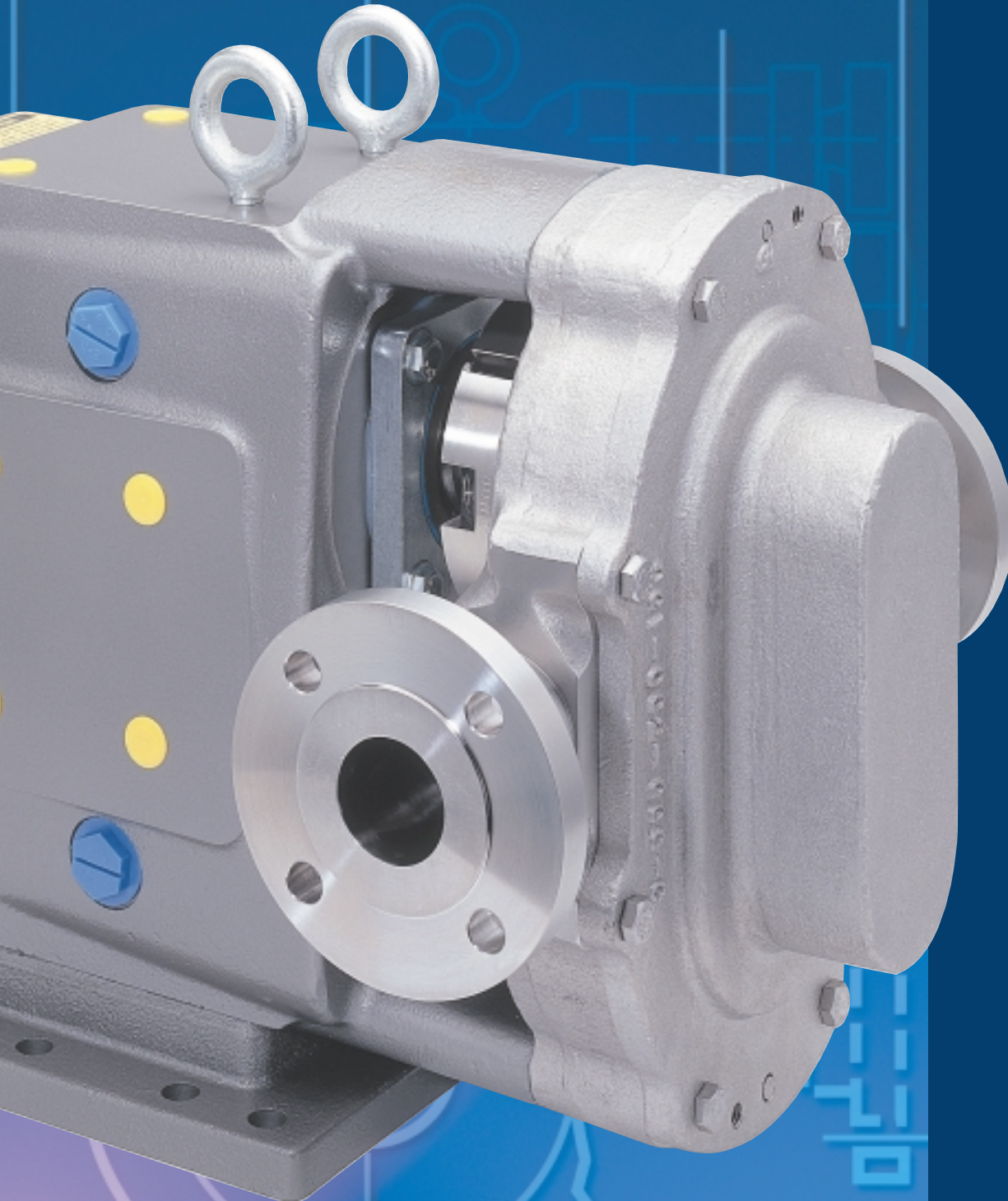

INDUSTRIAL ROTARY PD PUMPS

Long-life engineering features. High volumetric efficiency and low shear.

For more than half a century, Waukesha Cherry-Burrell has been a leader in the design, manufacturing and application of external circumferential piston (ECP) style, rotary positive displacement pumps. Waukesha Cherry-Burrell PD pumps are in service around the world in thousands of challenging chemical and industrial applications.

Users of Waukesha Cherry-Burrell PD pumps benefit from decades of continuing product improvement. Steady advances in design, metallurgy and fabrication techniques have yielded progressively higher levels of performance and service life.



Features

- **316 stainless steel body, cover and shafts.**
- **Exclusive, non-galling Waukesha "88" alloy rotors standard,** permits running at tighter clearances and pumping a wide range of viscosities.
- **Very low shear,** product not damaged during pumping.
- **Wide selection of commercial seals and packing.**

Long-life features

- **200 psi (13.8 bar) pressure capability.**
- **Heavy duty bearing frame.**
- **Double tapered roller bearings on all models** except 5040.
- **Grease lubed bearings** for positive lubrication to all bearings over entire speed, temperature and pressure range.
- **Body retaining screws** for maintaining mechanical seal loading and body position during inspection.
- **Steel-It Paint.**
- **Remanufacturing Program** to extend life and reduce costs.

Available options

- **High strength 17-4 PH shafts** for severe duty applications.
- **300 lb & DIN flanges,** and **NPT** port connections.
- **Stainless steel bearing retainers (NEW).**
- **Bearing isolators** protect bearings from contamination **(NEW).**
- **Jacketed or vented covers.**
- **Waukesha (ISR) Integral Speed Reducers,** eliminates coupling alignment and saves space.
- **Single, double, cartridge mechanical seals & packing.**
- **Optional port sizes** on 5040 thru 5060 models.
- **Side mount pedestals** for vertical porting.
- **Hot and front face rotor clearances,** for high temperature fluids.
- **Alloy 88 & Rulon cover bushings.**
- **Ceramic coated packing sleeves.**

Universal 5000 Series

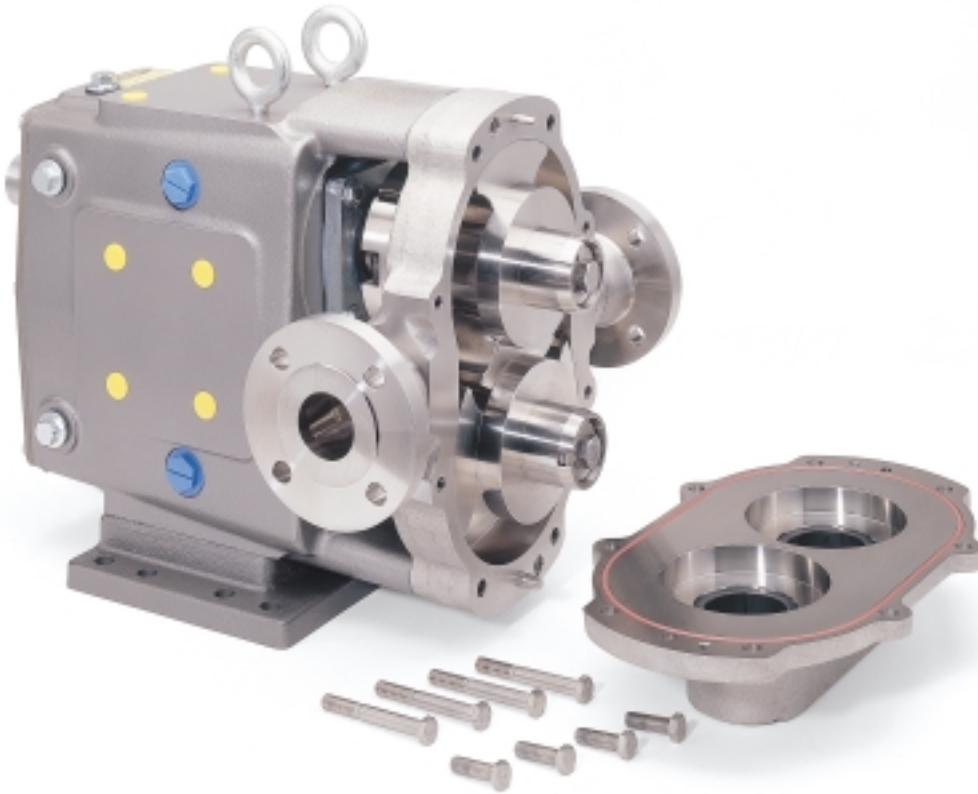

Installation flexibility

- **Bi-directional flow.** Rotors, locked in place, rotate securely in either direction. No flow direction/shaft position specifications.
- **Versatile 3-Way mounting** of gearcase, including vertical alignment of ports.
- **Upper or lower shaft position.**

Typical product applications

Solvents

Acetone
Carbon "Tet"
Spirits
M.E.K.

Oils & Lubricants

Crude Oil
Bunker Oil
Lubricant Oil
Fuel Oils
Greases
Oil Additives

Other

Acids
Alkalies
Animal Fats
Soaps
Sludges
Ammonium Nitrate
Polymers
Resins
Printing Ink
Paper Coatings
Urea
Glue
Latex
Lacquer



All the traditional Waukesha Cherry-Burrell values.

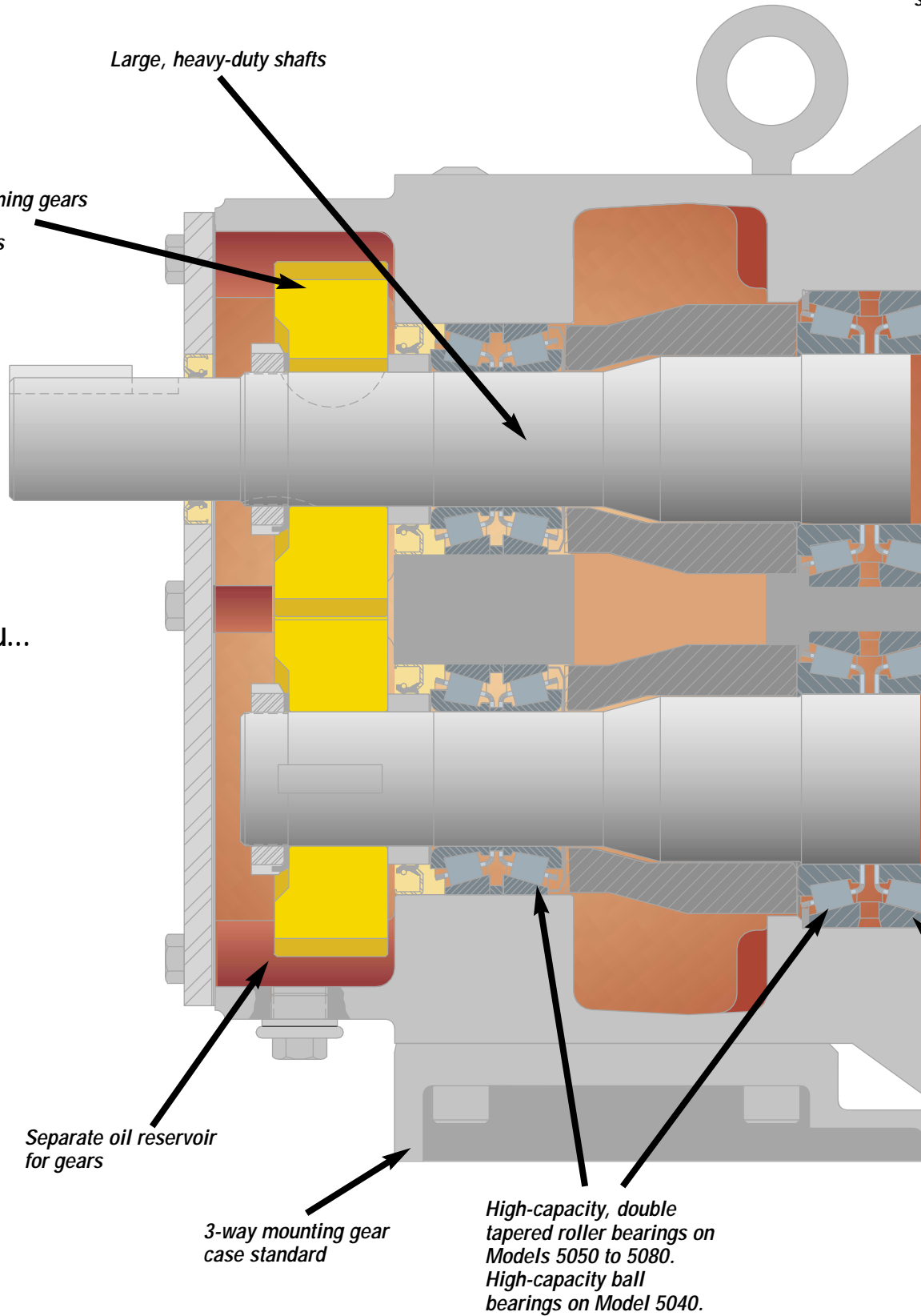

The Waukesha Cherry-Burrell Universal 5000 Series gives you...

High pressure capability:
200 psi/13.8 bar*.

Long service life: High capacity components for long trouble-free service.

Metal rotor: Waukesha "88" non-galling alloy, for close running clearance.

*For higher pressures, consult the factory.

Seal Options

Commercial mechanical seal and packing options for every service

316 stainless steel; design conforms to CE and ASME standards

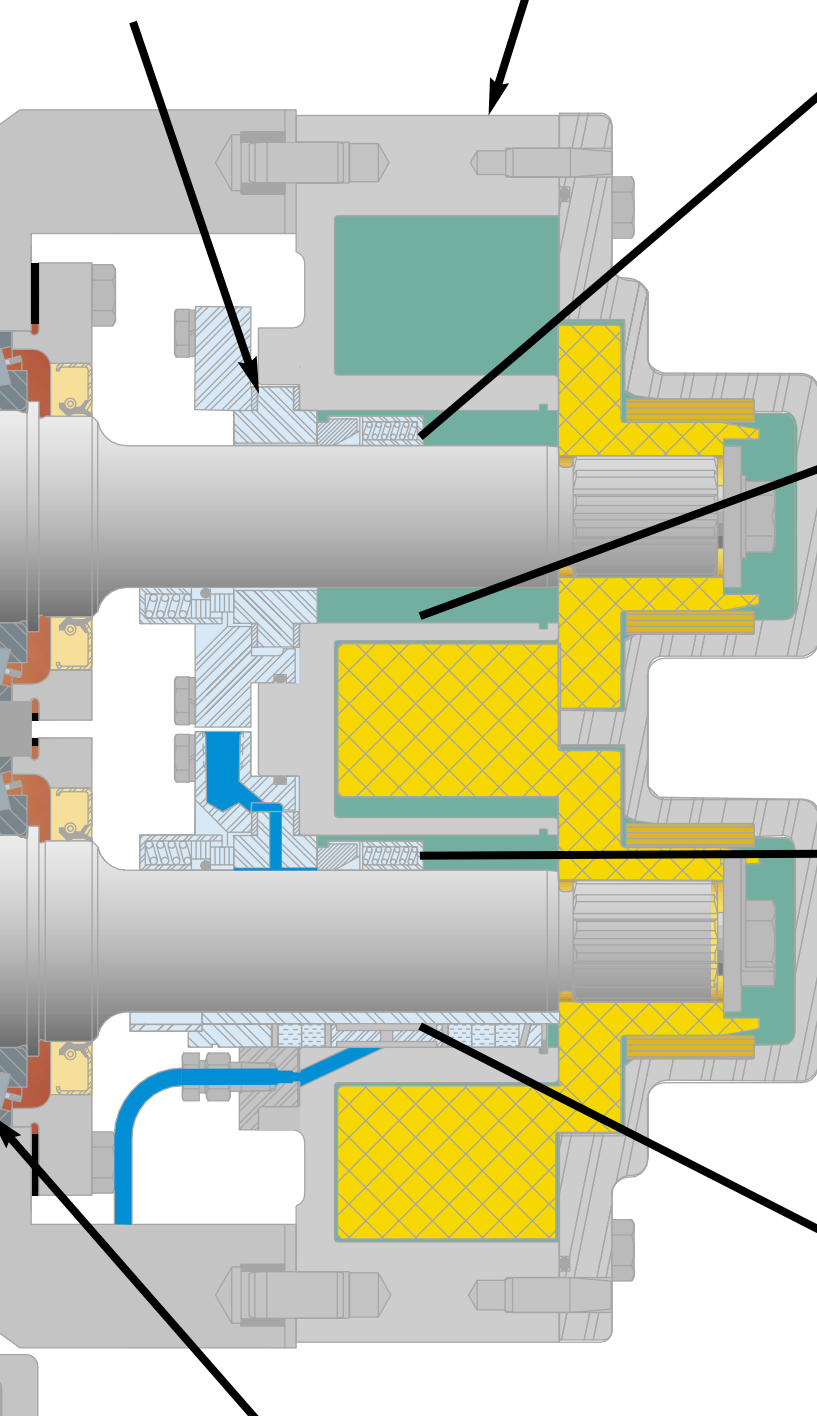

Front bearing fixed; rear bearing floating. Better control of thermal expansion when handling hot products.

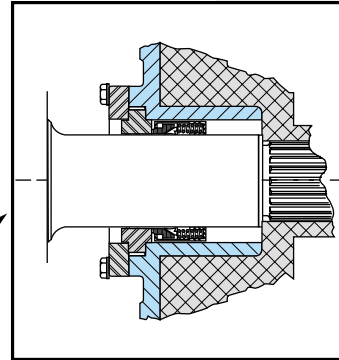

Single Inner Mechanical Seal

J. Crane Type 9 with carbon and ceramic seal faces standard.

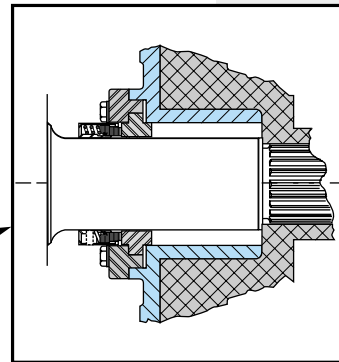

Single Outer Mechanical Seal

J. Crane Type 8B2 with carbon and ceramic seal faces standard.

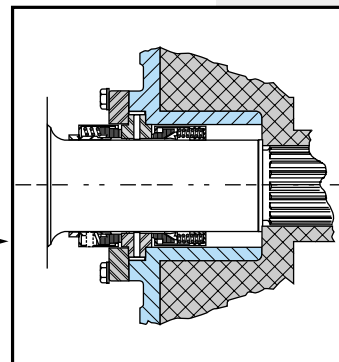

Double Mechanical Seal

Used with flushing fluid to cool, lubricate, flush away residue. Best arrangement for severe service. Combines above single inner and outer seals.

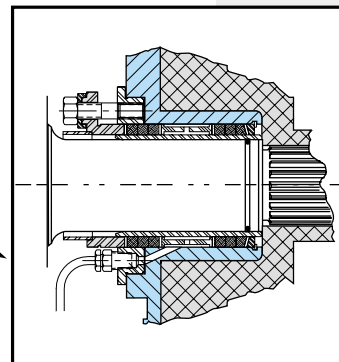

Packing

J. Crane Style 1335 TFE impregnated braided acrylic with SS sleeve standard.

Elastomer choices:

- Buna-N
- Fluorocarbon
- EPDM
- Silicone
- PTFE Encapsulated
- Kalrez®

Mechanical seal material options:

- Carbon
- Ceramic
- Silicon Carbide
- Tungsten Carbide

Cartridge seal
Consult factory.

DIMENSIONS

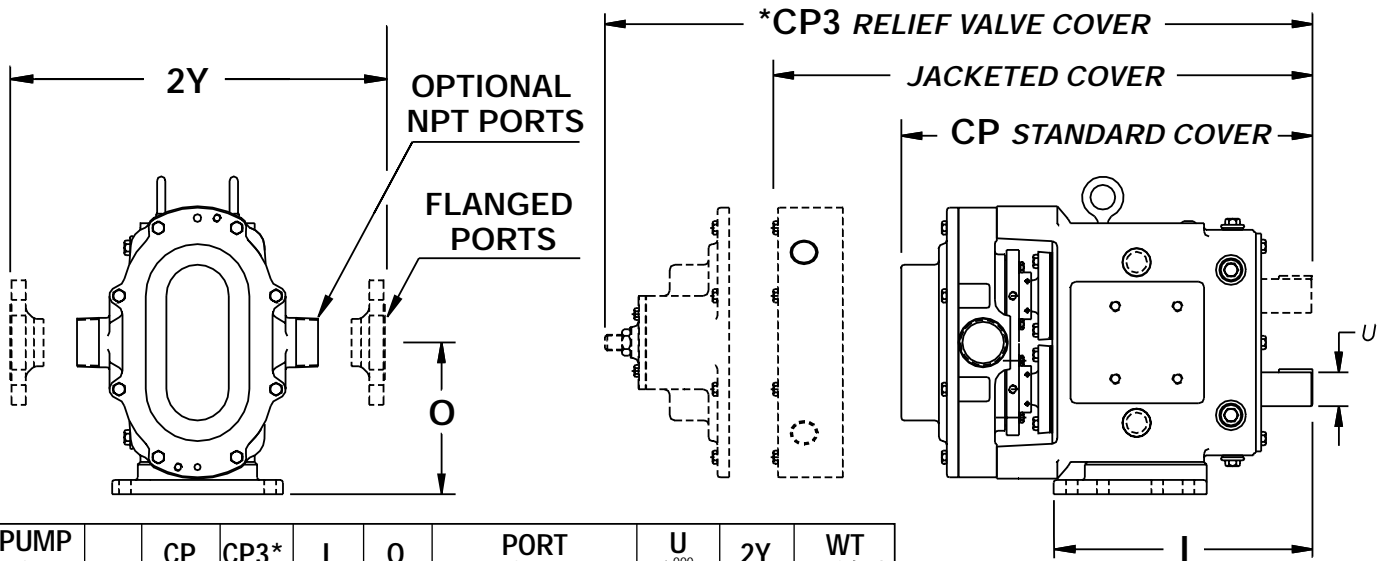

PUMP MODEL		CP	CP3*	I	O	PORT SIZE	U +0.000 -0.001	2Y	WT LBS/KG
5040	IN	16.52	18.64	8.83	5.21	1-1/2" - 150# Flange	1.250	11.91	100
	MM	419	473	224	132	-	31.75	303	45
5050	IN	19.83	23.08	12.49	7.31	2" - 150# Flange	1.625	13.25	240
	MM	504	586	317	186	-	41.28	337	109
5060	IN	20.78	24.03	12.49	7.31	2-1/2" - 150# Flange	1.625	13.50	245
	MM	528	610	317	186	-	41.28	343	111
5070	IN	26.31	28.50	15.29	9.38	4" - 150# Flange	2.000	14.75	475
	MM	668	724	388	238	-	50.80	375	215
5080	IN	30.17	34.05	17.80	10.38	6" - 150# Flange	2.375	16.00	810
	MM	766	865	452	264	-	60.33	406	367

*NOTE: CP3 is the maximum dimension for all vented and jacketed cover options.



Specifications

PUMP MODEL	DISPLACEMENT PER REVOLUTION	NOMINAL CAPACITY* TO	INLET AND OUTLET	OPTIONAL INLET AND OUTLET	PRESSURE RANGE**	MAXIMUM RPM	TEMP RANGE**
5040	0.060 GAL. (0.227 LITER)	36 GPM (8.2 m ³ /hr.)	1 1/2"	2"	200 PSI (13.8 bar)	600	(-)40° F/C to 300°F (149°C)
5050	0.153 GAL. (0.579 LITER)	90 GPM (20.4 m ³ /hr.)	2"	2 1/2"	200 PSI (13.8 bar)	600	
5060	0.254 GAL. (0.961 LITER)	150 GPM (34.1 m ³ /hr.)	2 1/2"	3"	200 PSI (13.8 bar)	600	
5070	0.440 GAL. (1.666 LITER)	260 GPM (59.1 m ³ /hr.)	4"		200 PSI (13.8 bar)	600	
5080	0.754 GAL. (2.854 LITER)	450 GPM (102.2 m ³ /hr.)	6"		200 PSI (13.8 bar)	600	

*For capacities above 450 to 935 GPM, see bulletin FH-1725 on 420/520 UHC (ECP Rotors) and FH-1733 on 420/520 UHCL (Lobe Rotors).

**Contact application engineering for higher pressure or higher temperature applications.

Time-tested Waukesha Cherry-Burrell rotary pump; external circumferential piston (ECP) operating principle

In the Waukesha Cherry-Burrell design, arc-shaped “pistons” (rotor wings) travel in annular-shaped cylinders machined in the pump body; the resulting long sealing path reduces slippage and produces a smooth flow of product without destructive pulses or pressure peaks and without valves or complex parts.

Exclusive Waukesha Cherry-Burrell design features

For Low Viscosity Fluids, rotors, made of exclusive Waukesha “88” alloy, can be run with close clearance to the 316 stainless steel fluid head, without galling or seizing should inadvertent pressure surges cause contact. The close clearances combined with the rotor geometry, which gives a long sealing path between the pump inlet and outlet, means low slip operation. As a result, you achieve: high volumetric efficiency, good priming ability, metering capability and good flow control.

For High Viscosity Fluids, the large fluid cavities of the rotors ... plus the large, easy entry anti-cavitation ports ... allow efficient pumping of high viscosity fluids, slurries or even liquids with large chunks or particles.

For Non-Lubricating and Abrasive Fluids, the unique Waukesha Cherry-Burrell design has no bearings in the fluid being pumped, no sliding or rolling contact and no rotor-to-rotor contact. This produces MAXIMUM SERVICE LIFE even under severe operating conditions.

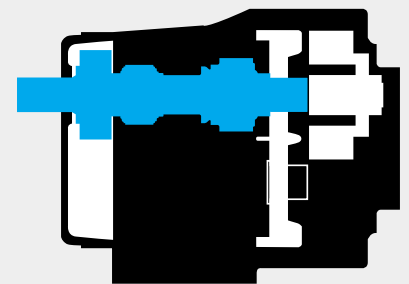
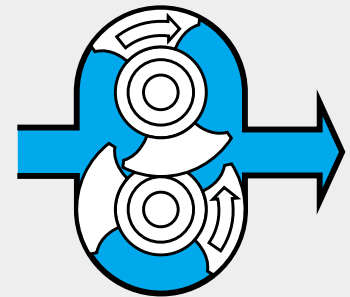
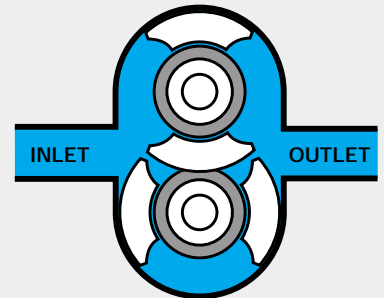
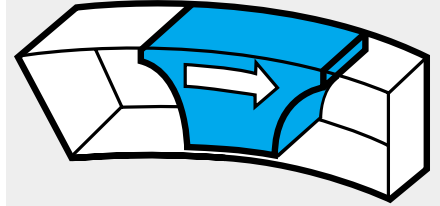

When it is time to repair ...

*Waukesha Cherry-Burrell offers the following options
– you pick the one that meets your needs.*

Factory Remanufacturing Program – WCB traditional program

- No need to return your pump until you receive your new remanufactured pump.
- Substantial savings over new pump.
- New pump performance and warranty.
- New pumps eligible for Remanufacturing Program twice.
- See Bulletin FH-1728 for more details.

WCB Certified Pump Repair Centers

- Local distributors with factory trained and certified service technicians.
- Quick local response.
- Genuine WCB parts.
- Flexible repair programs to meet your needs.
- Local warranty.

Waukesha Cherry-Burrell Warranty

Seller warrants its products to be free from defects in materials and workmanship for a period of one (1) year from the date of shipment. This warranty shall not apply to products which require repair or replacement due to normal wear and tear or to products which are subjected to accident, misuse or improper maintenance. This warranty extends only to the original buyer. Products manufactured by others but furnished by seller are exempted from this warranty and are limited to the original manufacturer's warranty.

Waukesha Cherry-Burrell

611 Sugar Creek Road

Delavan, WI 53115 USA

Tel: 1-800-252-5200 or 262-728-1900

Fax: 1-800-252-5012 or 262-728-4904

E-mail: custserv@gowcb.com

Web site: www.gowcb.com



**Waukesha
Cherry-Burrell**

**ISO 9001
CERTIFIED**



FH-1710

TA-1M-0801JA

Printed in U.S.A.

Effective 08/01